



ESCORTS
CONSTRUCTION EQUIPMENT

CT SMART 15

Smart City
Smart Solution

**6^m LOWEST
TURN
RADIUS**

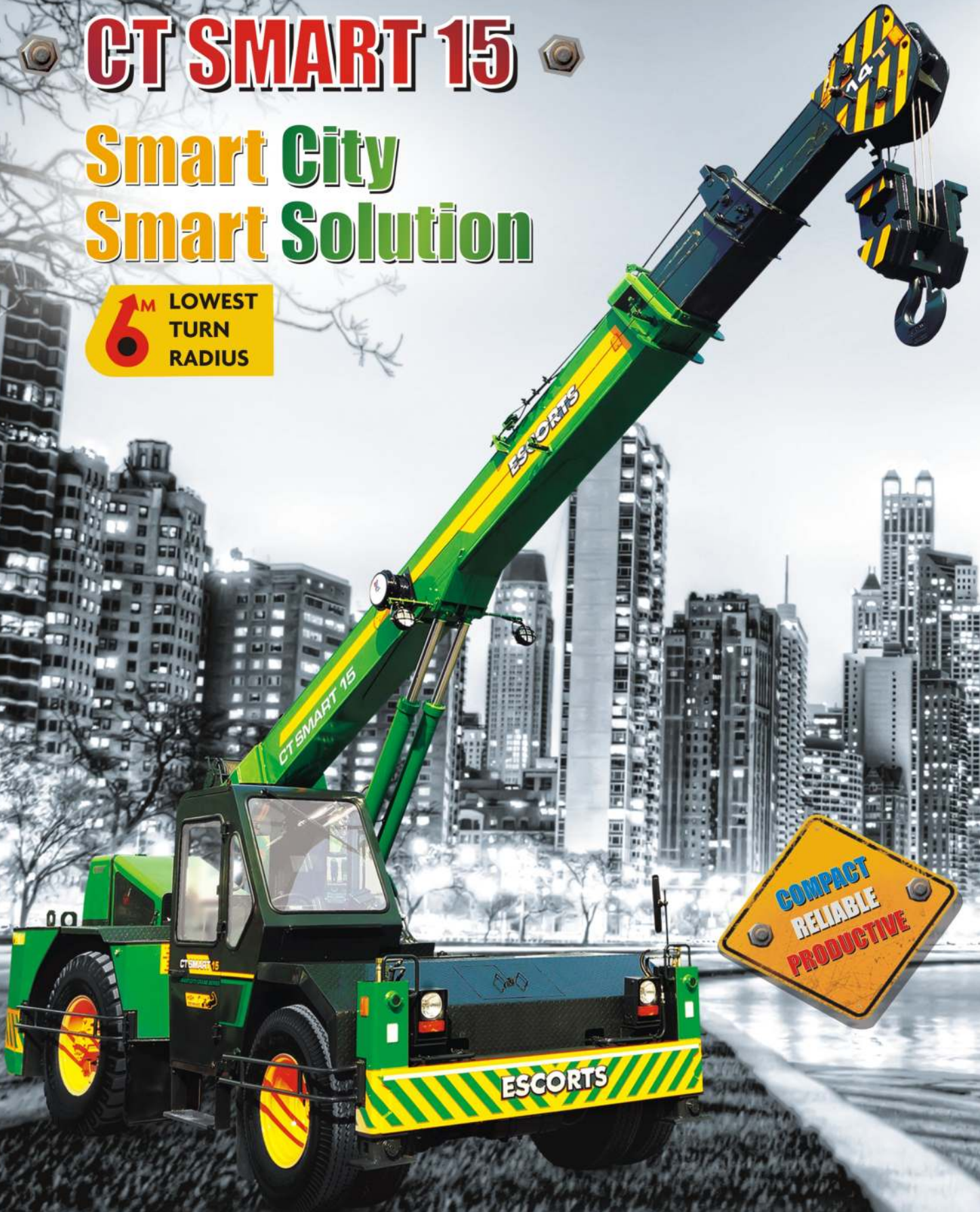

COMPACT
RELIABLE
PRODUCTIVE

CT SMART 15

Specification

RATED CAPACITY

- 14 Tonne @ 1.5 m radius
- 1.5 Tonne @ 10.95 m radius (20° articulation)
- 1.2 Tonne @ 10.95 m radius (40° articulation)
- Max Hook Height: 13.8 m with 3 part boom

SPEED

- Max: 38 KMPH
- Creep: 1.2 KMPH
- Gradeability: 40% unladen

DRIVE

- 2 Wheel Drive

ENGINE

- Diesel Engine of VOLVO EICHER make,
- Model E483 TCI, Turbo Charged water cooled
- Developing 80 HP @ 2400 rpm or Equivalent Engine
- Enhanced fuel efficiency by optimized power to wt ratio

TRANSMISSION

- Synchromesh Gearbox with Auxiliary Gearbox
- Speed: 10 Forward and 2 Reverse

CLUTCH

- Single, Dry type friction clutch plate

BRAKES

- Service: Front- Shoe brake operated by wheel cylinder
- Rear: Fully air operated 'S' cam brakes
- Parking: Air operated, spring actuated fail safe brakes on rear wheels

AXLES

- Front: Non Drive, part of Chassis
- Rear: VOLVO EICHER make and mounted with two semi elliptical springs

HYDRAULIC SYSTEM

- Main pump of 46 cc/rev
- Control valve (Main)- 3 spool control valve with built in pressure relief valve
- Control valve (Outrigger)- 2 spool control valve

ELECTRICAL SYSTEM

- 24V, DC

TYRES

- Front: 11.00X20-16PR (4 nos.)
- Rear: 14.00X25- 20PR (2 nos.)

STEERING

- Full power orbitrol with twin hydraulic double acting rams 40° articulation on either side

BOOM

- 3 part hydraulically powered & fully synchronised

HOIST

- Hydraulically operated with 6 Falls
- Heavy Duty Winch built in safety brakes

WHEEL BASE

- 3.5 m

DIMENSIONS

- Overall length: 8500 mm
- Overall width: 2550 mm
- Overall height: 3200 mm

WHEEL TRACK

- Front: 1930 mm
- Rear: 1825 mm

OPERATIONAL WEIGHT

- Front Axle: 4800 Kg
- Rear Axle: 10100 Kg
- Total: 14900 Kg

TURNING RADIUS

- 6 m

OPTIONAL ACCESSORIES

- SLI with Hydraulic Cut off & Articulation Switch
- AC Cabin
- Fire Extinguisher
- Tyre Guard
- Helper Seat with platform
- Rear View Camera (Display)
- Equipment Monitoring System (EMS)
- Beacon Light
- Fly Jib

CT SMART 15

Features



SLI monitoring system



LCD for rear view camera



SPACIOUS CABIN



Control of lever for ease of operation



Equipment Monitoring System and FM radio with speakers



Mobile charger



Volvo Eicher E483 TC 80 HP fuel efficient engine with 10 forward and 2 reverse synchromesh gearbox



Heavy duty rear drive axle



Heavy duty winch



Only crane with a lifting capacity of 14 ton at snatch block



Outriggers for safety



Heavy duty rear tyres 14.00x25- 20PR Tyre guards for safety

CT SMART 15

Reach Diagram

LOAD CHART CT SMART 15

● Highest Performance with Lowest Boom Overhang of 3.33m

● Highest Safety with Auto derated Load chart in Articulation

● Most Compact Crane with 8.5m Length

● Highest Manuverability with Lowest Turning Radius of 6m

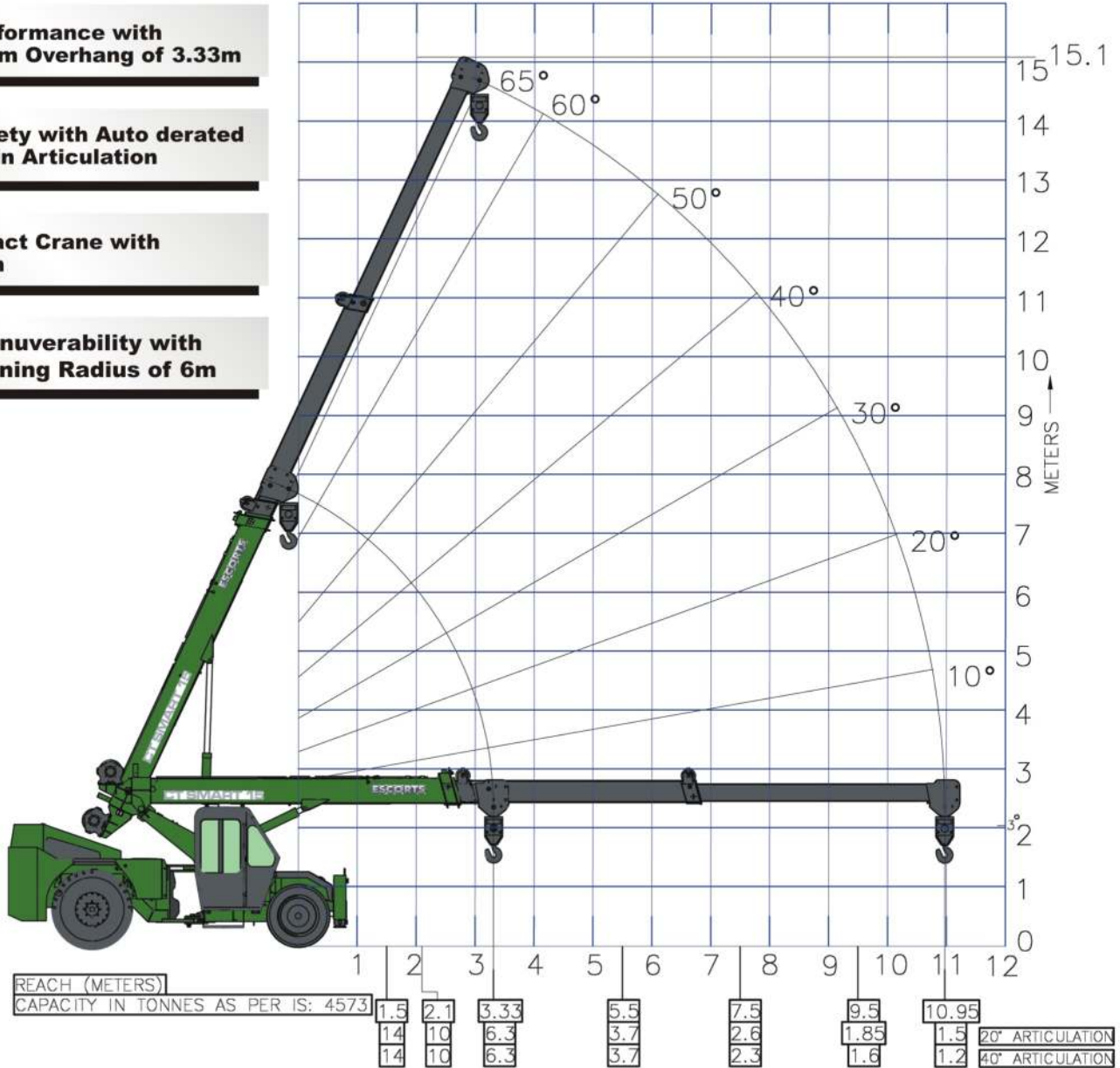

● Max load lifting capacity: 14T @ 1.5m

● Max boom height: 17.3m with Flyjib

● Load chart designed for 20° & 40° articulation

● 3-part, 15.1m fully powered boom



ESCORTS
CONSTRUCTION EQUIPMENT

Escorts Construction Equipment: Plot No. 219, Sector- 58, Ballabhgarh- 121 004, Haryana (INDIA)
Tel.: 0129-2306574/2306598/2306571 Fax: 0129-2306463 **Toll Free No.-1800- 180- 4488**
(Timings: 9.30 am - 5.00 pm, Monday to Friday) **e-mail:** ece.marketing@escorts.co.in
Website: www.escortsece.com